

### 1. Overview

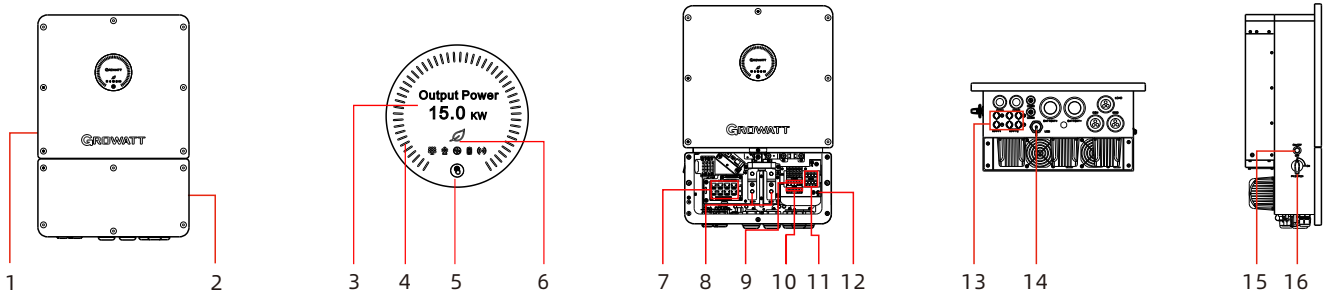

- |                          |                                |                            |                              |
|--------------------------|--------------------------------|----------------------------|------------------------------|
| (1) Top cover plate      | (2) Bottom cover plate         | (3) OLED Display screen    | (4) Battery status indicator |
| (5) Push button          | (6) System indicator           | (7) Communication terminal | (8) Battery wiring terminal  |
| (9) Load wiring terminal | (10) Generator wiring terminal | (11) Grid wiring terminal  | (12) PE wiring terminal      |
| (13) PV wiring terminal  | (14) USB port                  | (15) Battery button        | (16) PV switch               |

#### ⚠ Note:

- The content of this document is continually reviewed and amended, where necessary. Growatt reserves the right to make changes to the material at any time and without notice. Unless otherwise agreed, this document is for quick installation guidance only. All information and suggestions in this document do not constitute a warranty of any kind, express or implied. Growatt reserves all rights for final explanation.
- This document is for quick installation guidance only. For details, please refer to the User Manual.
- Machine damage caused by failure to follow the instructions is not covered under any warranty.

### 2. Installation

#### System overview

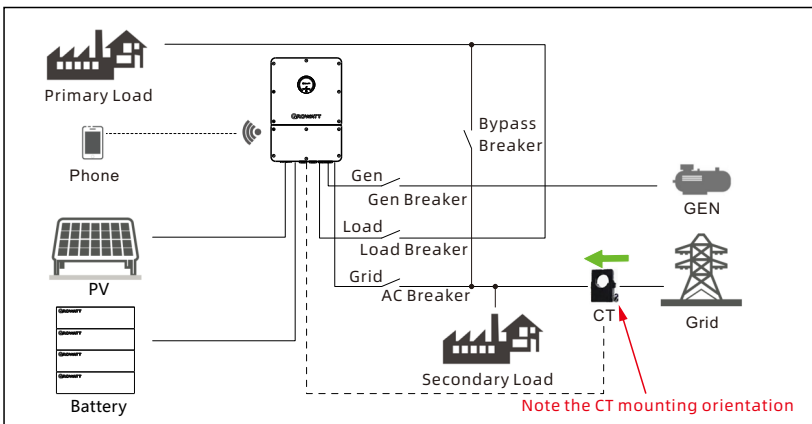

#### 2.1 Installation requirements

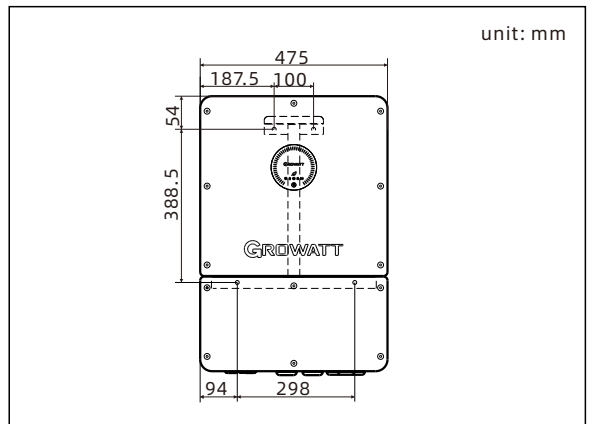

#### 2.2 Wall-mounted installation

<p>1. Mark the hole positions</p>	<p>2. Drill: Depth 70mm Diameter <math>\phi</math>10mm</p>	<p>3. Install the expansion screws</p> <p>10-11mm</p> <p>Remove the flat pad before installation</p>	<p><b>⚠ Note:</b></p> <ol style="list-style-type: none"> <li>When determining the installation position of the inverter, please consider the position of the batteries and the distribution panel.</li> <li>When drilling holes, avoid the water pipes and power cables buried in the wall.</li> </ol>
<p>4. Install the wall mount</p> <p>Torque: 396Kgf.cm</p>	<p>5. Install the machine</p>	<p>6. Stationary machine</p> <p>Torque: 50Kgf.cm</p>	

### 3. Connecting cables

Please prepare the cables listed below before electrical connections.

No.	Cable	Type	Recommended specifications
1	PE cable	Multi-core copper cable (yellow-green)	6mm <sup>2</sup>
2	Grid/Generator/Load cable	Multi-core copper cable	10mm <sup>2</sup>
3	PV input cable	PV cable	4mm <sup>2</sup> -6mm <sup>2</sup>
4	Battery input cable	Multi-core copper cable (orange and black)	50mm <sup>2</sup> /120mm <sup>2</sup>
5	COM1/COM2 communication cable	Standard network cable-568B	/
6	COM3 communication cable	Multi-core copper cable	22AWG
7	COM4 communication cable	Multi-core copper cable	22AWG

**⚠ Note:**

1. Make sure all switches are OFF before connecting the cables. For personal safety, do not operate when power-on.
2. If the diameter of the cable does not match the terminal, or the cable is aluminum wire, please contact our after-sales personnel.

#### 3.1 Grounding

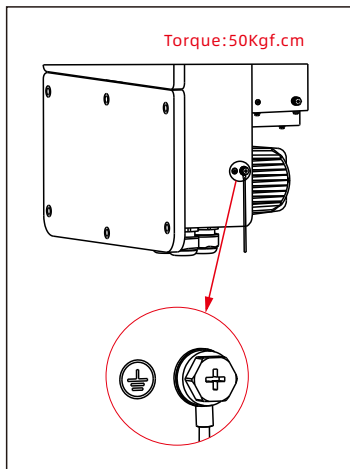

#### 3.2 Connection of AC side

1. Remove the lower cover

2. Connect the PE cable Torque:20Kgf.cm

3. Connect the AC cable

Refer to step 2 for terminal crimping

**⚠ Note:**

1. After connecting the cables, tighten the PG cable glands to ensure reliable protection
2. Do not install the bottom cover plate at this step; it should be installed after all internal cables are connected.

#### 3.3 Connection on the PV side

##### 3.3.1 Assembling the PV connector

1

unit: mm

2

Ensure that the cable cannot be pulled out from the terminal after crimping.

3

Pull the PV cables back to check that they are connected securely.

4

Ensure secure connection by tightening the locking nut.

5

Make sure the cable polarity is correct.

##### 3.3.2 Connecting the PV cables

1

2

**⚠ Note:**

1. Before installing the PV terminals, please confirm that the PV input voltage and current do not exceed the MPPT limits.
2. When installing the PV terminals, identify the positive and negative terminals and connect them to the inverter respectively following the color convention.
3. A "click" sound will be heard when the terminal is connected. Please gently pull the PV cable back to make sure it is securely connected.
4. Models 4K, 5K, and 6K only use ports ② and ③, and port ① does not.
5. Models 8K and 10K only use ports ① and ③, and port ② does not.

### 3.4 Connection on the battery side

Select 3.4.1 or 3.4.2 based on requirements

#### 3.4.1 Single-cluster battery wiring

1

Single-hole stoppers

1.1 18 unit: mm

1.2 Heat shrink tubing

1.3

2

2.1

2.2

2.3

3

Torque:198Kgf.cm

**⚠ Note:**

- Before installing the battery terminals, please ensure that the battery input voltage and current are within the acceptable range.
- When installing battery terminals, ensure the correct polarity.
- When securing the OT terminal, ensure that the fixing screws are tightened. Please gently pull back the battery cable to ensure a secure connection.

#### 3.4.2 Dual-cluster battery wiring

1

Double-hole rubber stopper

1.1 18 unit: mm

1.2 Heat shrink tubing

1.3

2

2.1

2.2

2.3

3

Torque:198Kgf.cm

**⚠ Note:**

- Before installing the battery terminals, please ensure that the battery input voltage and current are within the acceptable range.
- When installing battery terminals, ensure the correct polarity.
- When securing the OT terminal, ensure that the fixing screws are tightened. Please gently pull back the battery cable to ensure a secure connection.
- The rubber plug needs to be replaced with a double-hole rubber plug of 2-φ14 for the wiring of the double group battery.

### 3.5 Installing the communication cable

Please refer to the user manual for details on PIN and meter wiring

COM1、COM2 terminal wiring

COM3、COM4 terminal wiring

Pin	COM3	Pin	COM4
1	REPO.WIT	7	\ 11 CT_S+
2	GND.S	8	\ 12 CT_S++
3	DG_START+	9	CT_R+ 13 CT_T+
4	DG_START-	10	CT_R- 14 CT_T-
5	NTC.BAT1 OUT		
6	NTC.BAT1 OUT.G		

Communication port description								
Pin	BMS1	BMS2	RS485_1	RS485_2	METER	DI	PARA-IN	PARA-OUT
1	BAT RS485_B	\	RS485_1B	RS485_1B	Rs485_2B	DRM1/5	\	\
2	BAT RS485_A	\	GND.S	GND.S	GND.S	DRM1/6	GND.S	GND.S
3	BAT1 DI_1	\	\	\	\	DRM1/7	Sc_A/H	Sc_A/H
4	BAT1 CAN_H	\	RS485_1B	Rs485_1B	\	DRM1/8	PL_CANH	PL_CANH
5	BAT1 CAN_L	\	RS485_1a	RS485_1A	RS485_2A	REF	PL_CANL	PL_CANL
6	BAT1 DI_2	\	\	\	\	COM	Sc_B/L	Sc_B/L
7	BAT1 WAKE-	\	RS485_3B	RS485_3B	\	\	GND.S	Slave_CAN
8	BAT1 WAKE+	\	RS485_3A	Rs485_3A	\	\	Master_CAN	GND.S

### 3.6 Fixed lower cover plate

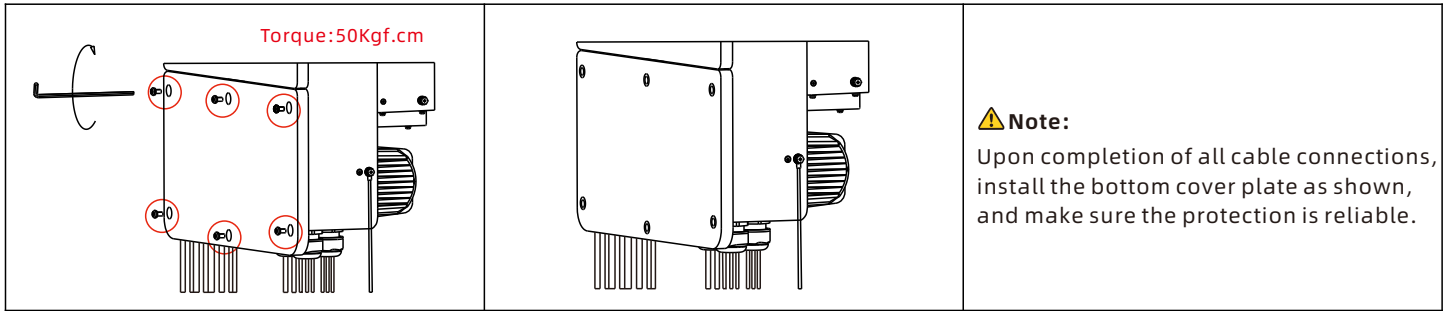

**⚠ Note:**  
Upon completion of all cable connections, install the bottom cover plate as shown, and make sure the protection is reliable.

### 3.7 Installing the datalogger

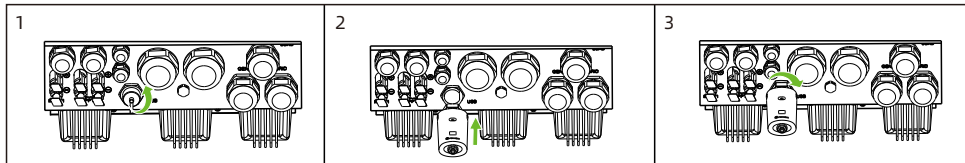

Follow the installation steps:  
1. Remove the waterproof cover from the USB port.  
2. Plug in the datalogger.  
3. Secure the datalogger.

## 4. Post-installation check

Number	Checking item	Number	Checking item
1	The hybrid inverter is installed correctly and reliably.	2	Ground cables are connected securely.
3	All switches are in the OFF position.	4	All cables are connected correctly and securely.
5	The lower cover is secured.	6	All the unused connectors are sealed.
7	Put away the unused accessories.	8	The installation position is clean and tidy.

## 5. Powering on/off the inverter

### ⚠ Note:

Before turning the inverter on, please make sure the PV input voltage and current are within the MPPT limits .

Perform the following steps to power on the system:

1. Connect the PV cable , then turn on the PV switch.
  2. Turn on the breaker between the grid and the inverter.
  3. Turn on the breaker between the battery and the inverter, then turn on the switch of the battery. Wait for 30 seconds, and turn on the battery switch of the inverter.
  4. The system will be powered on automatically when all the requirements are met.
- To shut down the system, you need to send a shutdown command on the APP or website. Wait until the system is completely powered off, then turn off the switches in reverse order.

## 6. Description of the display panel

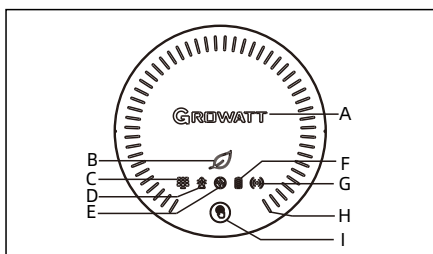

Indicator	Function	Indicator	Function
A	OLED display screen	F	Battery connection indicator
B	System indicator	G	Communication/GEN indicator
C	PV indicator	H	Battery status indicator
D	On-grid indicator	I	Push button
E	Off-grid indicator		

## 7. Service and contact

### Shenzhen Growatt New Energy Co., Ltd

4-13/F, Building A, Sino-German (Europe) Industrial Park, Hangcheng Blvd, Bao'an District, Shenzhen, China

T +86 755 2747 1942

E service@ginverter.com

W en.growatt.com



Download Manual



Growatt New Energy

GR-UM-475-A-02 (PN: 044.0140502)